

www.prexiso-eu.com

PREXISO

- EN USER MANUAL
- DE BENUTZERHANDBUCH
- FR MANUEL UTILISATEUR
- IT MANUALE UTENTE
- ES MANUAL DE USUARIO
- NL HANDLEIDING
- TR KULLANIM KILAVUZU
- DK BRUGERMANUAL
- FI OHJEKIRJA
- NO BRUKERMANUAL

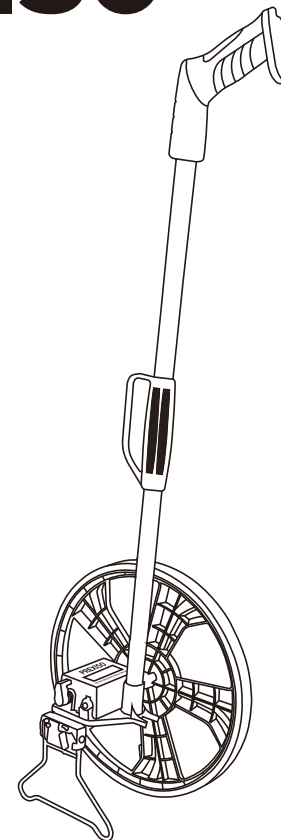
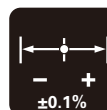

Prexiso AG
CH-6300 Zug / Switzerland



www.prexiso-eu.com

IMPORTANT:
Read before Using

EN



The safety instructions and the user manual should be read through carefully before the product is used for the first time.

SAFETY INSTRUCTION:

Be sure to return the counter to zero before measuring.

1. If a line measured, the accuracy of the measurement is guaranteed.
2. Don't measure the uneven surface, or it will reduce the accuracy of the measurement.
3. Don't measure in the rain for long.
4. Don't measure in a high temperature environment. Don't store the instrument at high temperature.
5. Do not use this instrument as a child's toy to avoid unwanted damage.

PROHIBITED USE

- Using the product without instruction
- Using outside the stated limits
- Deactivation of safety systems and removal of explanatory and hazard labels
- Opening of the equipment by using tools (screwdrivers, etc.)
- Carrying out modification or conversion of the product
- Use of accessories from other manufacturers without express approval

LIMITS OF USE

Never attempt to repair the product yourself. In case of damage, contact a local dealer. Refer to section "Technical data", the device is designed for using in areas which is habitable for humans.

Do not use the product in explosion hazardous areas or in aggressive environments.

**AREAS OF RESPONSIBILITY
RESPONSIBILITIES OF THE PERSON IN
CHARGE OF THE INSTRUMENT:**

- To understand the safety instructions on the product and the instructions in the User Manual.
- To be familiar with local safety regulations relating to accident prevention.
- Always prevent access to the product by unauthorized personnel.

FUNCTION

This mechanical measuring wheel is a kind of distance tools of measurement. Widely used in traffic road site measurement, ordinary construction, pave road, or yard survey. This measuring wheel can measure up to 9999.9 m. The folding rod makes the measuring wheel easy to carry.

PRODUCT OVERVIEW

- A. Rubber handle
- B. Folding rod
- C. Rod locking sleeve
- D. Measuring wheel with 1m circumference
- E. Kickstand(fold-out)
- F. Moving pointer for start and end position
- G. Mechanical counter
- H. Reset knob

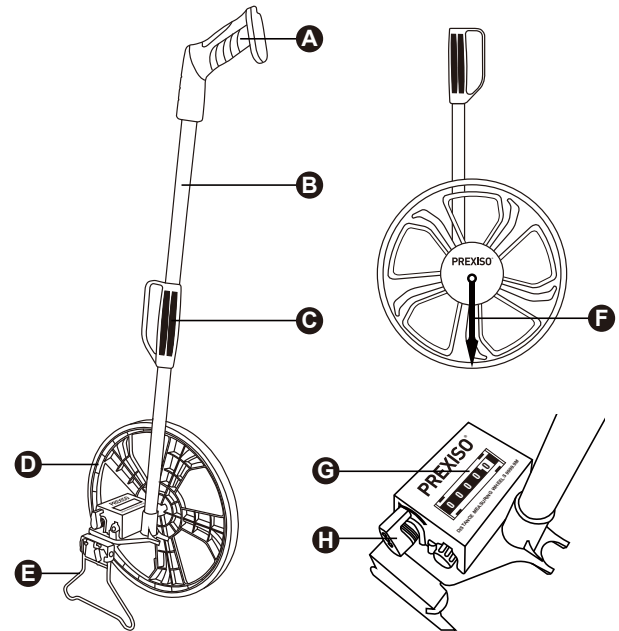

OPERATION INSTRUCTION

1. Fold out the measuring wheel.

Fold out and straighten the rod, move the rod locking sleeve to fix the rod.

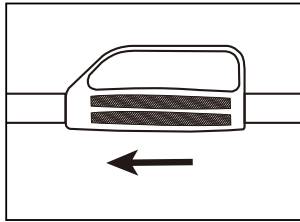
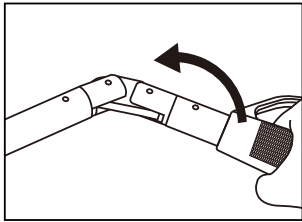

2. Reset the measurement

Toggle the Reset knob to make the mechanical counter to zero.

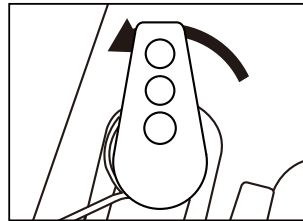

3. Measure the distance from wall to wall

- Position the wheel against the wall and reset the counter.
- Push the wheel straight to the other wall.
- Read the measured value and add diameter of the wheel when measurement is finished.

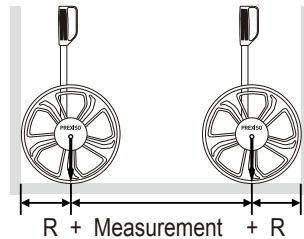

4. Measure the distance from spot to wall

- Position the wheel from the beginning spot and reset the counter.
- Push the wheel straight to the wall.
- Read the measured value and add radius of the wheel when measurement is finished.

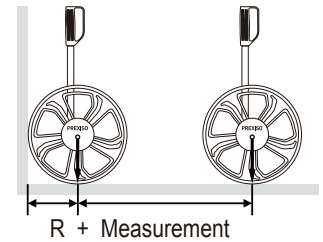

5. Measure the distance from spot to spot

- Position the wheel from the beginning spot and reset the counter.
- Push the wheel straight to the other spot.
- Read the measured value.

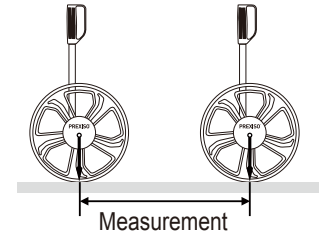

6. Fold for carrying

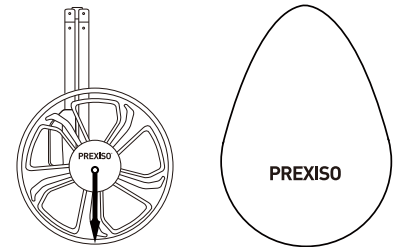
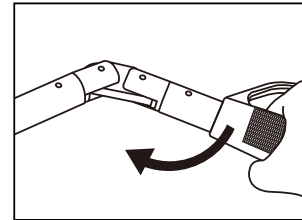

Technical specification

Accuracy	± 10 cm / 100 m
Range	0-9999.9m
Circumference of measuring wheel	1000mm
Diameter of measuring wheel	318mm
Radius of measuring wheel	159mm
Operating temperature	-10°C to 45°C (14°F-113°F)
Dimensions (W x H x D)	318x180x1000mm / 318x180x500mm (folded)
Weight	1538g

WARRANTY

The Instrument PWX-1000M has a two-year warranty. For further information on this, contact your dealer. This warranty is void if product is used for commercial purposes. This warranty is not transferable and does not cover products damaged by misuse, neglect, accident, alterations or use and maintenance other than that specified in the owner's manual. This warranty does not apply to any expendable parts that can wear from normal use. This warranty excludes any accessories.